

## MODEL: SL-HACCP-100W

### Application

Designed for HACCP and NFS Light solution  
For Food and beverage processing industrial

### Specification

#### Electrical Data

Power : 100W ± 5%  
Input : 100-277VAC 50-60Hz  
Power Factor : >0.95  
THD : <15%  
SPD : 4 KV

#### Photometric Data

Luminous Flux : 14,000 lm  
Efficiency : 140lm/W  
CCT : 3000K / 4000K / 6000K  
CRI : >80  
LED CHIP : Lumiled  
Beam Angle : 60 / 90 / 120  
LED Certificate : HACCP / NFS Approved

#### Mechanical Data

Weight : 5.9 KGS  
IP rate : IP66 / IK08  
Body Material : Aluminum Diecast  
Lens Material : Polycarbonate (PC)

### Ordering Data

Model	Watt	CCT	Beam
SL-HACCP-100W	100W	3000K	60D
		4000K	90D
		6000K	120D

### Accessories Optional



Microwave Sensor



Reflector

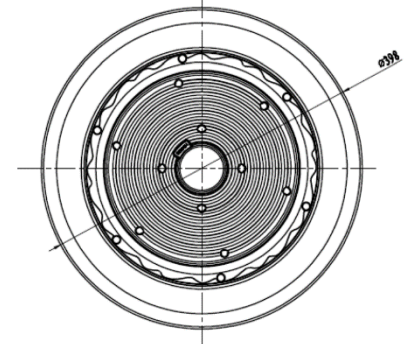
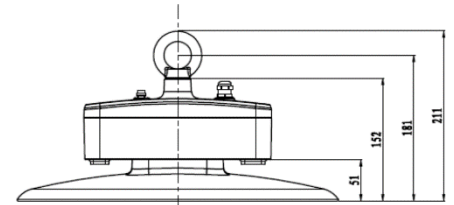

LM79

LM80